



# Dell PowerConnect W-AP175 Outdoor Access Point

## Installation Guide

The Dell PowerConnect W-AP175 is a resilient, environmentally hardened, outdoor rated, dual-radio, dual-band IEEE 802.11 a/b/g/n wireless access point. This outdoor access point is part of Dell's comprehensive wireless network solution. The W-AP175 works only in conjunction with an Dell PowerConnect W-Series controller and each AP can be centrally managed, configured, and upgraded through the controller.



---

**NOTE:** The W-AP175P requires ArubaOS 5.0.2.1 or later. The W-AP175AC and W-AP175DC require ArubaOS 6.1.2.3 or later.

---

There are three versions of the W-AP175, which mainly differ in the way they receive power.

- W-AP175P: PoE+ powered (802.3at)
- W-AP175AC: AC powered (100-240 V AC)
- W-AP175DC: DC powered (12-48 V DC)



---

**NOTE:** The W-AP175AC/DC can function as a Power Sourcing Equipment (PSE) device by providing power through its ethernet port in compliance with the IEEE 802.3af standard.

---

## Guide Overview

- [“W-AP175 Hardware Overview” on page 3](#) provides a detailed hardware overview of the three W-AP175 models.
- [“Outdoor Planning and Deployment Considerations” on page 7](#) provides key questions to ask and items to consider when deploying an outdoor wireless network.
- [“Installing Antennas” on page 11](#) describes how to installing antennas.
- [“Weatherproofing Connections” on page 12](#) provides instructions on weatherproofing the AP's connectors.
- [“Installing the W-AP175” on page 20](#) describes the multi-step process for a successful installation and deployment of an W-AP175.
- [“Safety and Regulatory Compliance” on page 30](#) provides an overview of safety and regulatory compliance information.

## W-AP175 Operations

- Wireless access point (IEEE 802.11 a/b/g/n)
- Wireless air monitor (IEEE 802.11 a/b/g/n)
- Enterprise mesh point
- Enterprise mesh portal
- Protocol-independent networking functionality
- W-AP175P: IEEE 802.3at Power over Ethernet+ (PoE+) compatible
- W-AP175AC and W-AP175DC: IEEE 802.3af Power Sourcing Equipment (PSE) device

## Package Contents

- W-AP175 Access Point
- W-AP175 Mounting Bracket
- Solar Shield
- Pole Anchors x 2
- M4 x 16 bolts, flat washers, and spring washers x4 (These bolts are attached to the solar shield)
- M6 x 30 bolts, flat washers, and spring washers x2
- M4 x 12 bolt, external-tooth washer, and OT copper lug x1
- M8 x 110 bolt, flat washers, spring washers, and nuts x4
- Metal Weatherproof Caps x2 for use on unused antenna interfaces
- RJ-45 Connector Kit with plastic RJ-45 connector (W-AP175P only)
- RJ-45 Connector Kit with metal RJ-45 connector (W-AP175AC/DC only)
- USB Console Cable
- Installation Guide



---

**NOTE:** Inform your supplier if there are any incorrect, missing, or damaged parts. If possible, retain the carton, including the original packing materials. Use these materials to repack and return the unit to the supplier if needed.

---

# W-AP175 Hardware Overview

The following section describes the hardware features of the W-AP175.

**Figure 1** W-AP175 Overview (W-AP175P shown)

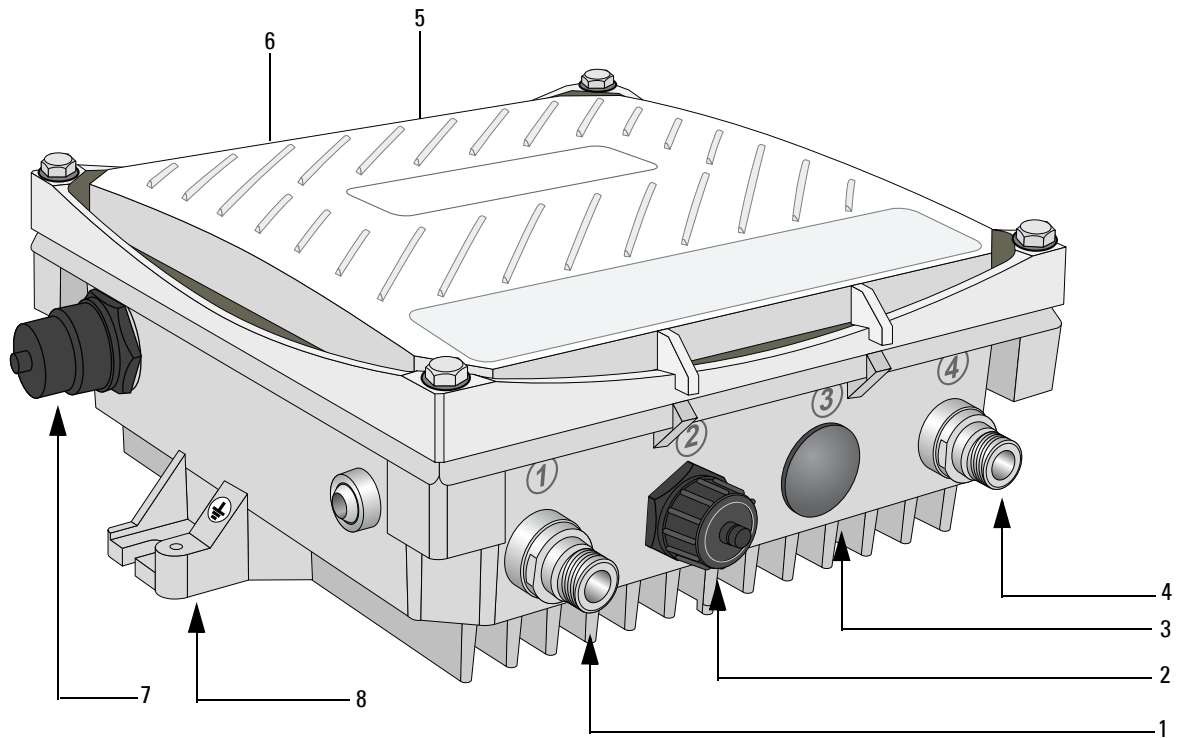

- |   |   |   |                             |
|---|---|---|-----------------------------|
| 1 | Antenna Interface (Radio 1)   | 5 | Antenna Interface (Radio 0) |
| 2 | USB Console Interface   | 6 | Antenna Interface (Radio 1) |
| 3 | Reserved (W-AP175P) or<br>Power Interface (W-AP175AC and W-AP175DC) | 7 | Ethernet Interface (PoE)    |
| 4 | Antenna Interface (Radio 0)   | 8 | Grounding Point             |

## Antenna Interface

The W-AP175 requires the use of detachable outdoor-rated antennas. Select the correct antenna type to support the required frequency band (2.4 or 5 GHz) and the desired coverage pattern.

The W-AP175 is equipped with four, female N-type antenna interfaces; two on the top of the AP and two on the bottom. The interfaces are grouped into diversity pairs, one pair is marked R0 (Radio 0) and the other pair marked as R1 (Radio 1). R0 supports the 5 GHz frequency band and R1 supports the 2.4 GHz radio band.

## USB Console Interface

A USB serial console port is provided for connection to a terminal, allowing direct local management. Use the included USB console cable to connect to the AP. You can download the necessary driver for USB-UART adapter from [download.dell-pcw.com](http://download.dell-pcw.com) under Tools & Resources.

Use the following setting to access the terminal:

**Table 1** Console Settings

Baud Rate	Data Bits	Parity	Stop Bits	Flow Control
9600	8	None	1	None

## Power Interface

The type of power interface on your W-AP175 depends on which model you have purchased.

- W-AP175P: This version does not include a power interface since it is only powered by PoE+ (802.3at).
- W-AP175AC: 1x AC power connector
- W-AP175DC: 1x DC power connector



---

**CAUTION:** Do not connect a DC power cable to an W-AP175AC or an AC power cable to a W-AP175DC.

---

### CAUTION:

For the W-AP175AC, only use the AC power cord with model number CBL-AC-INTL.

ACケーブル (CBL-AC-INTL) は、W-AP175AC製品のみで使用可能です。

For the W-AP175DC, only use DC power cord with model number CBL-DC-WW.

DCケーブル (CBL-DC-WW) は、W-AP175DC製品のみで使用可能です。



## Ethernet Interface

The W-AP175 is equipped with a 10/100/1000Base-T Gigabit Ethernet port for wired network connectivity. On the W-AP175P, this port also supports IEEE 802.3at Power over Ethernet (PoE), accepting 48 VDC as a standards-defined powered device (PD) from a power sourcing equipment (PSE) device, such as a PoE midspan injector. Inversely, the W-AP175AC and W-AP175DC can act as a PSE device to provide IEEE802.3af PoE power to devices connected to the ethernet port.

## Grounding Point

Always remember to protect your W-AP175 by installing grounding lines. The ground connection must be complete before connecting power to the W-AP175 enclosure. Ensure that the resistance is less than 5 ohm between the ground termination point and the grounding tier.

## W-AP175P LED Status Indicators

The W-AP175 include visual indicators for power, link, and radio status. Additionally, each radio has a four-LED array that indicates received signal strength (RSSI).



**NOTE:** The RSSI LED indicators represent varying degrees in the RSSI level. The absence of a signal is indicated by no LED response, and full signal strength is indicated when all four LEDs are active and lit.

**Figure 2** LED Layout

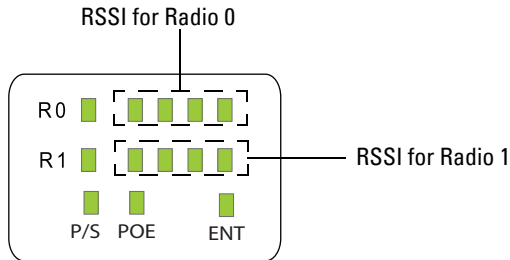

Table 2 lists the meanings of the LEDs on the W-AP175P outdoor access point.

**Table 2** W-AP175P LED Status Indicators

LED	Function	Indicator	Status
P/S	AP Power/Ready Status	Off	No power to AP
		Blinking	Device booting, not ready
		On	Device ready
POE	N/A	N/A	Not currently used
ENT	LAN/Network Link Status	Off	Ethernet link unavailable
		On (Amber)	10/100 Mbs ethernet link negotiated
		On (Green)	1000 Mbs ethernet link negotiated
		Blinking	Traffic on ethernet link
R0	Radio 0 Status	Off	Radio 0 disabled
		On (Amber)	Radio 0 enabled in WLAN mode
		Blinking	Air Monitor (AM) mode
R1	Radio 1 Status	Off	Radio 1 disabled
		On (Blue)	Radio 1 enabled in WLAN mode
		Blinking	Air Monitor (AM) mode
RSSI (Radio 0)	RSSI Level for Radio 0	Off	RSSI disabled/no signal
		4 Step Progressive Bars (Red)	Each bar represents a progressive increase in signal strength, with 4 bars representing maximum signal strength (100%).
		25/50/75/100%	Minimum data rate: One lit LEDs Maximum data rate: Four lit LEDs

**Table 2** W-AP175P LED Status Indicators (Continued)

LED	Function	Indicator	Status
RSSI (Radio 1)	RSSI Level for Radio 1	Off	RSSI disabled/no signal
		4 Step Progressive Bars (Blue)  25/50/75/100%	Each bar represents a progressive increase in signal strength, with 4 bars representing maximum signal strength (100%). Minimum data rate: One lit LEDs Maximum data rate: Four lit LEDs

### W-AP175AC/DC LED Status Indicators

The W-AP175 include visual indicators for power, link, heat and radio status. Additionally, each radio has a four-LED array that indicates received signal strength (RSSI).



**NOTE:** The RSSI LED indicators represent varying degrees in the RSSI level. The absence of a signal is indicated by no LED response, and full signal strength is indicated when all four LEDs are active and lit.

**Figure 3** LED Layout

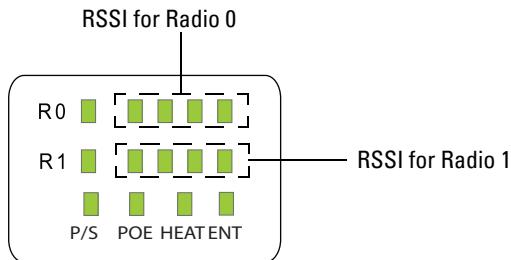

Table 3 lists the meanings of the LEDs on the W-AP175AC/DC outdoor access points.

**Table 3** W-AP175AC/DC LED Status Indicators

LED	Function	Indicator	Status
P/S	AP Power/Ready Status	Off	No power to AP
		Blinking	Device booting, not ready
		On	Device ready
POE	Displays PSE power output status	Off	Non-powered device ( $0\Omega < R_{port} < 200\Omega$ ) or Port open ( $R_{port} > 1M\Omega$ )
		Green	Port on ( $25k\Omega$ ) <ul style="list-style-type: none"> <li>1 Flash: Low signature resistance (<math>300\Omega &lt; R_{port} &lt; 15k\Omega</math>)</li> <li>2 Flashes: High signature resistance (<math>33k\Omega &lt; R_{port} &lt; 500k\Omega</math>)</li> <li>5 Flashes: Port overload fault</li> <li>9 Flashes: Power management allocation exceeded</li> </ul>
Heat	Displays the heating status of low temperature	Off	Unit is not in heating status
		Blinking (Blue)	Unit is pre-heating

**Table 3** W-AP175AC/DC LED Status Indicators (Continued)

LED	Function	Indicator	Status
ENT	LAN/Network Link Status	Off	Ethernet link unavailable
		On (Amber)	10/100 Mbs ethernet link negotiated
		On (Green)	1000 Mbs ethernet link negotiated
		Blinking	Traffic on ethernet link
R0	Radio 0 Status	Off	Radio 0 disabled
		On (Amber)	Radio 0 enabled in WLAN mode
		Blinking	Air Monitor (AM) mode
R1	Radio 1 Status	Off	Radio 1 disabled
		On (Blue)	Radio 1 enabled in WLAN mode
		Blinking	Air Monitor (AM) mode
RSSI (Radio 0)	RSSI Level for Radio 0	Off	RSSI disabled/no signal
		4 Step Progressive Bars (Red)  25/50/75/100%	Each bar represents a progressive increase in signal strength, with 4 bars representing maximum signal strength (100%).  Minimum data rate: One lit LEDs Maximum data rate: Four lit LEDs
RSSI (Radio 1)	RSSI Level for Radio 1	Off	RSSI disabled/no signal
		4 Step Progressive Bars (Blue)  25/50/75/100%	Each bar represents a progressive increase in signal strength, with 4 bars representing maximum signal strength (100%).  Minimum data rate: One lit LEDs Maximum data rate: Four lit LEDs

## Outdoor Planning and Deployment Considerations

Prior to deploying an outdoor wireless network, the environment must be evaluated to plan for a successful Dell WLAN deployment. Successfully evaluating the environment enables the proper selection of Dell APs and antennas and assists in the determination of their placement for optimal RF coverage. This process is considered WLAN or RF planning.

### Scale Requirements

The potentially immense scale of outdoor deployments requires consideration of factors that may not be as important in a typical indoor deployment:

- **Range (distance):** Range or distance between APs must be taken into account during the planning phase. Available AP mounting locations are often far less flexible in an outdoor environment. Regardless of these outdoor restrictions, the desired goal is to achieve results similar to an indoor deployment: a “dense” RF deployment that supports advanced Aruba features, such as ARM, efficient client roaming, and failover.
- **Elevation:** Proper consideration and planning for elevation differences between APs (AP to AP) and AP to Client can be *critical* to success. To plan for these differences in elevation, it is important to understand the 3D coverage pattern provided by the antennas that will be deployed in the environment.
- **Non-Fixed Considerations:** The RF environment might change on a day to day basis. Keep non-fixed items, such as shipping containers, vehicles, and future building construction, in mind when planning for an outdoor deployment.

## Identifying Known RF Absorbers/Reflectors/Interferences Sources

Identifying known RF absorbers/reflectors/interference sources while out in the field during the installation phase is critical. Even though outdoor environments consist of fewer RF absorbers/reflectors/interference sources compared to indoor environments, ensure that these sources are identified and taken into consideration when installing and mounting an AP to its fixed outdoor location.

### RF Absorbers

- Cement/Concrete
- Natural Items: Trees/vegetation
- Brick

### RF Reflectors

- Metal Objects: Roof-installed air-conditioning equipment, chain link fences (depending on aperture size), other wire fences, or water pipes

### RF Interference Sources

- Other 802.11a/b/g/n or broadband access equipment operating nearby
- Industrial RF welding equipment or other Industrial, Scientific and Medical (ISM) equipment that utilizes RF to heat or alter the physical properties of materials
- Military, Commercial Aviation or Weather Radar Systems

## Line of Sight (Radio Path Planning)

A wireless bridge or mesh link requires a “radio line of sight” between the two antennas for optimum performance. The concept of radio line of sight involves the area along a link through which the bulk of the radio signal power travels. This area is known as the first Fresnel Zone of the radio link. For a radio link, no object (including the ground) must intrude within 60% of the first Fresnel Zone.

Figure 4 illustrates the concept of a good radio line of sight.

**Figure 4** *Line of Sight*

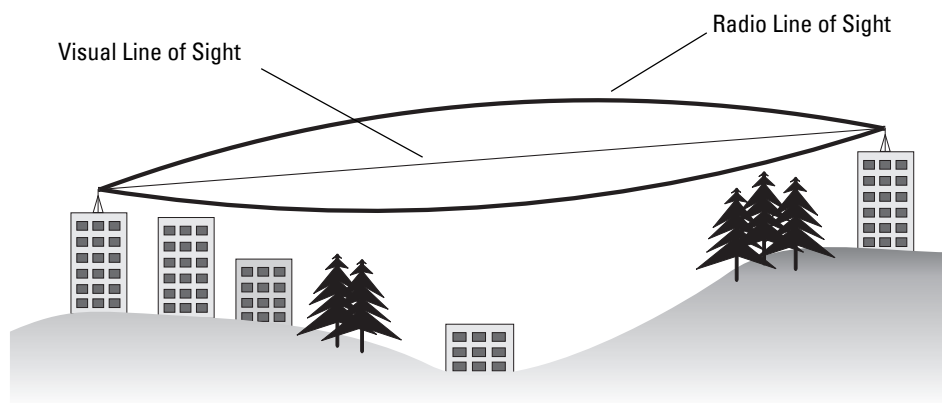

If there are obstacles in the radio path, there may still be a radio link but the quality and strength of the signal will be affected. Calculating the maximum clearance from objects on a path is important as it directly affects the decision on antenna placement and height. It is especially critical for long-distance links, where the radio signal could easily be lost.

When planning the radio path for a wireless bridge or mesh link, consider these factors:

- Avoid any partial line of sight between the antennas
- Be cautious of trees or other foliage that may be near the path, or may grow and obstruct the path.



- Be sure there is enough clearance from buildings and that no building construction may eventually block the path.
- For very long distance links, the curvature of the earth (20 cm per km) may need to be considered in the calculation of relative heights.
- Check the topology of the land between the antennas using topographical maps, aerial photos, or even satellite image data (software packages are available that may include this information for your area)
- Avoid a path that may incur temporary blockage due to the movement of cars, trains, or aircraft.

## Antenna Height

A reliable wireless bridge or mesh link is usually best achieved by mounting the antennas at each end high enough for a clear radio line of sight between them. The minimum height required depends on the distance of the link, obstacles that may be in the path, topology of the terrain, and the curvature of the earth (for links over 3 miles).

For long-distance links, the AP may have to be mounted on masts or poles that are tall enough to attain the minimum required clearance. Use the following table to estimate the required minimum clearance above the ground or path obstruction (for 5 GHz bridge links).

**Table 4** *Antenna Minimum Height and Clearance Requirements*

Total Link Distance	Max Clearance for 60% of First Fresnel Zone at 5.8 GHz	Approximate Clearance for Earth Curvature	Total Clearance Required at Mid-point of Link
0.25 mile (0.402 km)	4.6 ft (1.4 m)	0.007 ft (0.002 m)	4.6 ft (1.4 m)
0.5 mile (0.805 km)	6.2 ft (1.9 m)	0.03 ft (0.010 m)	6.2 ft (1.9 m)
1 mile (1.6 km)	8.9 ft (2.7 m)	0.13 ft (0.04 m)	8.9 ft (2.7 m)
2 miles (3.2 km)	12.5 ft (3.8 m)	0.5 ft (0.15 m)	13.1 ft (4.0 m)
3 miles (4.8 km)	15.4 ft (4.7 m)	1.0 ft (0.3 m)	16.4 ft (5.0 m)
4 miles (6.4 km)	17.7 ft (5.4 m)	2.0 ft (0.6 m)	19.7 ft (6.0 m)
5 miles (8 km)	20 ft (6.1 m)	3.0 ft (0.9 m)	23 ft (7.0 m)
7 miles (11.3 km)	23.6 ft (7.2 m)	6.2 ft (1.9 m)	30 ft (9.1 m)
9 miles (14.5 km)	27 ft (8.2 m)	10.2 ft (3.1 m)	37 ft (11.3 m)
12 miles (19.3 km)	30.8 ft (9.4 m)	18.0 ft (5.5 m)	49 ft (14.9 m)
15 miles (24.1 km)	34.4 ft (10.5 m)	28.0 ft (8.5 m)	62.7 ft (19.1 m)



**NOTE:** To avoid any obstruction along the path, the height of the object must be added to the minimum clearance required for a clear radio line of sight. Consider the following simple example, illustrated in [Figure 5](#).

**Figure 5** Antenna Height and Line of Sight

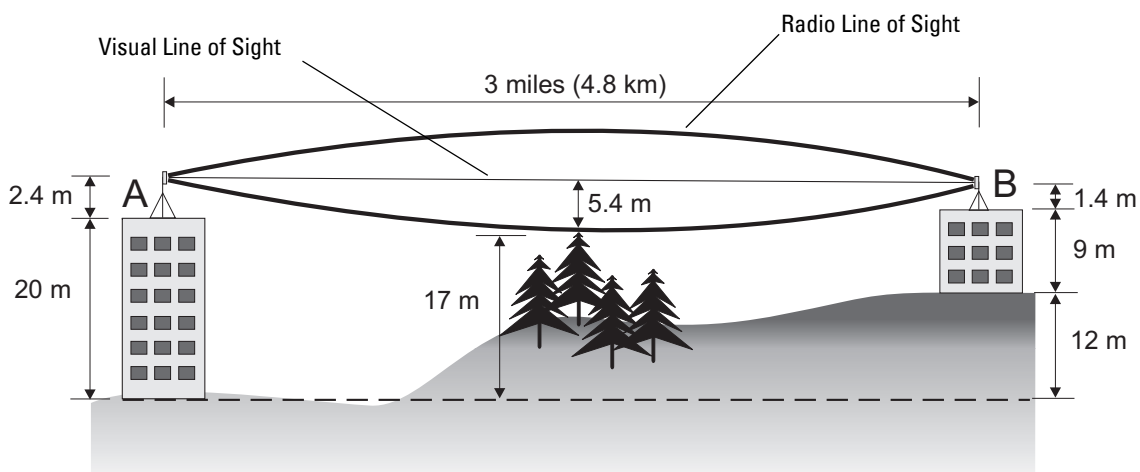

A wireless bridge or mesh link is deployed to connect building A to building B, which is located three miles (4.8 km) away. Mid-way between the two buildings is a small tree-covered hill. From the above table it can be seen that for a three-mile link, the object clearance required at the mid-point is 5.3 m (17.4 ft). The tree tops on the hill are at an elevation of 17 m (56 ft), so the antennas at each end of the link need to be at least 22.3 m (73 ft) high. Building A is six stories high, or 20 m (66 ft), so a 2.3 m (7.5 ft) mast or pole must be constructed on its roof to achieve the required antenna height. Building B is only three stories high, or 9 m (30 ft), but is located at an elevation that is 12 m (39 ft) higher than building A. To mount an antenna at the required height on building B, a mast or pole of 1.3 m (4.3 ft) is needed.



**CAUTION:** Never construct a radio mast, pole, or tower near overhead power lines.



**NOTE:** Local regulations may limit or prevent construction of a high radio mast or tower. If your wireless bridge or mesh link requires a high radio mast or tower, consult a professional contractor for advice.

## Antenna Position and Orientation

Once the required antenna height has been determined, other factors affecting the precise position of the wireless bridge or mesh link must be considered:

- Be sure there are no other radio antennas within 2 m (6 ft) of the wireless bridge or mesh link. These include other WiFi radio antennas.
- Place the wireless bridge or mesh link away from power and telephone lines.
- Avoid placing the wireless bridge or mesh link too close to any metallic reflective surfaces, such as roof-installed air-conditioning equipment, tinted windows, wire fences, or water pipes. Ensure that there is at least 5 feet clearance from such objects.
- The wireless bridge or mesh link antennas at both ends of the link must be positioned with the same polarization direction, either horizontal or vertical. Proper alignment helps to maximize throughput.

## Radio Interference

The avoidance of radio interference is an important part of wireless link planning. Interference is caused by other radio transmissions using the same or an adjacent channel frequency. You should first scan your proposed site using a spectrum analyzer to determine if there are any strong radio signals using the 802.11a/b/g channel frequencies. Always use a channel frequency that is furthest away from another signal.

If radio interference is still a problem with your wireless bridge or mesh link, changing the antenna direction may improve the situation.

## Weather Conditions

When planning wireless bridge or mesh links, you must take into account any extreme weather conditions that are known to affect your location. Consider these factors:

- **Temperature:** The wireless bridge or mesh link is tested for normal operation in temperatures from -30°C to 55°C. Operating in temperatures outside of this range may cause the unit to fail.
- **Wind Velocity:** The wireless bridge or mesh link can operate in winds up to 165 miles per hour. You must consider the known maximum wind velocity and direction at the site and be sure that any supporting structure, such as a pole, mast, or tower, is built to withstand this force.
- **Lightning:** To protect against lightning induced surges, the W-API75 requires lightning protection on the radio interface ports.



---

**CAUTION: A Dell Lightning Arrestor, AP-LAR-1, must be installed on each antenna port for protection against lightning induced surges. Failure to use an AP-LAR-1 can void the warranty of an Dell outdoor AP model and renders the AP susceptible to failure from lightning induced surges**

---

- **Rain:** The wireless bridge or mesh link is weatherproofed against rain. However, it is recommended to apply weatherproof sealing tape around the ethernet port and antenna connectors for extra protection. If moisture enters a connector, it may cause a degradation in performance or even a complete failure of the link.
- **Snow and Ice:** Falling snow, like rain, has no significant effect on the radio signal. However, a buildup of snow or ice on antennas may cause the link to fail. In this case, the snow or ice has to be cleared from the antennas to restore operation of the link.

## Ethernet Cabling

When a suitable antenna location has been determined, you must plan a cable route from the wireless bridge or mesh link outdoors to a suitable power and/or network source.

Consider these points:

- The ethernet cable length should never be longer than 90 m (295 ft).
- Determine a building entry point for the cable (if applicable).
- Determine if conduits, bracing, or other structures are required for safety or protection of the cable.
- For lightning protection at the power injector end of the cable, consider using a lightning arrestor immediately before the cable enters the building

## Grounding

It is important that the wireless bridge or mesh link, cables, and any supporting structures are properly grounded. Each W-API75 access point includes a grounding screw for attaching a ground wire.



---

**CAUTION: Be sure that grounding is available and that it meets local and national electrical codes. Ground the access point first using the external ground stud on the unit before making any other connection.**

---

## Installing Antennas

1. Before connecting the antennas, identify which of your antennas are 2.4 GHz and which are 5 GHz. On the W-API75, the 2.4 GHz antennas must be installed the R1 radio interfaces and the 5.0 GHz must be installed on the R0 radio interfaces.
2. After identifying which antennas will go where, install them by placing the antenna connector over the corresponding connector and the AP and turning the connector clockwise until hand tight. Repeat this process for each antenna.

3. Place the included metal weatherproof caps over any unused antenna interfaces by turning them clockwise until hand tight.

## Weatherproofing Connections

Weatherproofing your antenna and/or cable connections on your outdoor AP is essential to reliability and longevity of your product. This process prevents water from entering the AP or antennas through the connectors.

A good weatherproofing job consists of three wrappings:

1. electrical tape
2. butyl rubber
3. electrical tape

The first wrapping of tape should be at least two layers, followed by a single wrap of butyl rubber, and four-layer wrap of electrical tape. This provides good protection from water, heat, and other potential hazards that could damage your AP or antennas.

Additionally, wrap your connections such that water is always directed down and away from connections.

### Required Items and Tools

- 3/4" (19 mm) Vinyl Electrical Tape
- Butyl Rubber Tape
- Knife or Box Cutter

### Types of Connections

The following sections provide guidance on weatherproofing directly connected antennas ([Figure 6](#)) and cable connections ([Figure 7](#)). The same materials are needed for weatherproofing both types of connections but the procedure is slightly different. For weatherproofing directly connected antennas, see "[Weatherproofing Directly Connected Antennas](#)" on page 15. For weatherproofing cable connections, see "[Weatherproofing Cable Connections](#)" on page 18.

**Figure 6** *Directly Connected Antennas*

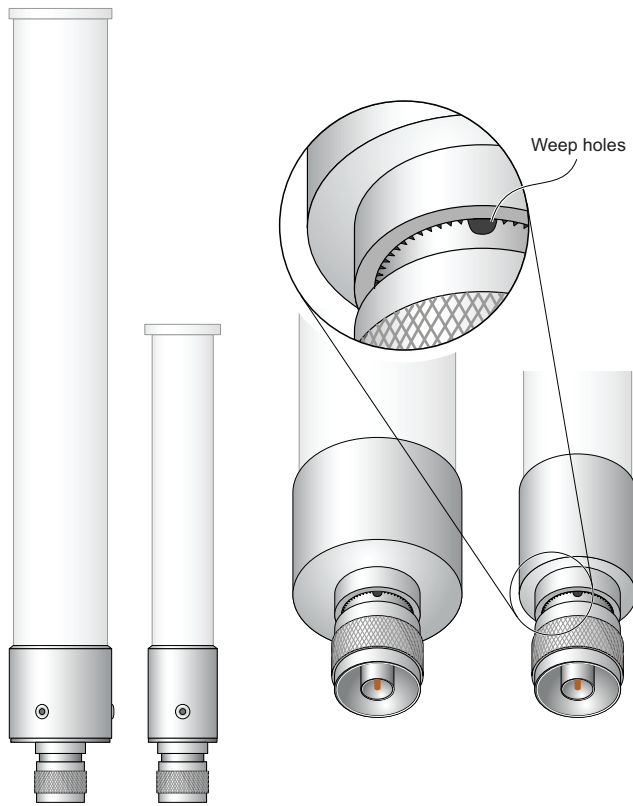

AP175\_11

**Figure 7** *Cable Connections*

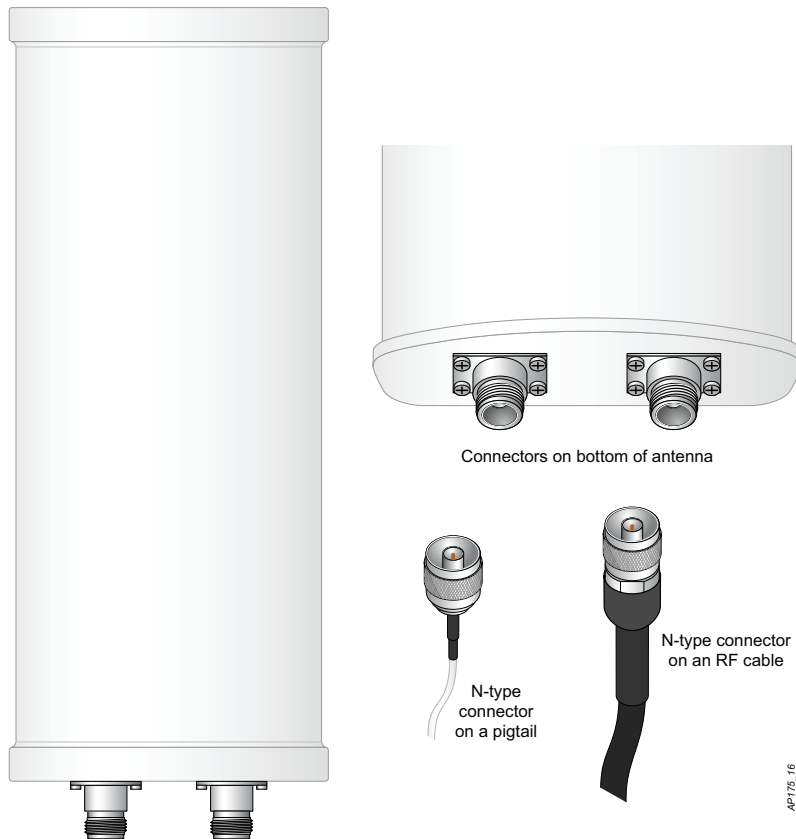

### **Important Points to Remember**

- Do not cover the weep holes on the antennas. Doing so can restrict the release of condensation from the antennas.
- Proper weatherproofing is not a fast process. Set aside ample time to complete the steps outlined below.
- When wrapping, make the each layer of tape as flat as possible. Wrinkles and folds in the tape create places for water and moisture to gather.

## Weatherproofing Directly Connected Antennas

### First Wrapping of Tape

1. Before wrapping the antennas, locate the weep holes (Figure 6). Weep holes allow condensation that has built up inside the antenna to escape.
2. Prepare the antenna connector by cleaning and drying it.
3. Cut a 4" (100 mm) strip of electrical tape from the roll. Pre-cutting the tape into strips makes it easier to maneuver the tape around the antennas and other components of the AP's case.
4. Beginning just below the weep holes, tightly wrap the connection with a layer of the 3/4" (19mm) electrical tape. Overlap the tape to a half-width.
5. Repeat steps 3 and 4 until the wrapping extends all the way to the AP's case.

**Figure 8** *First Wrapping of Tape*

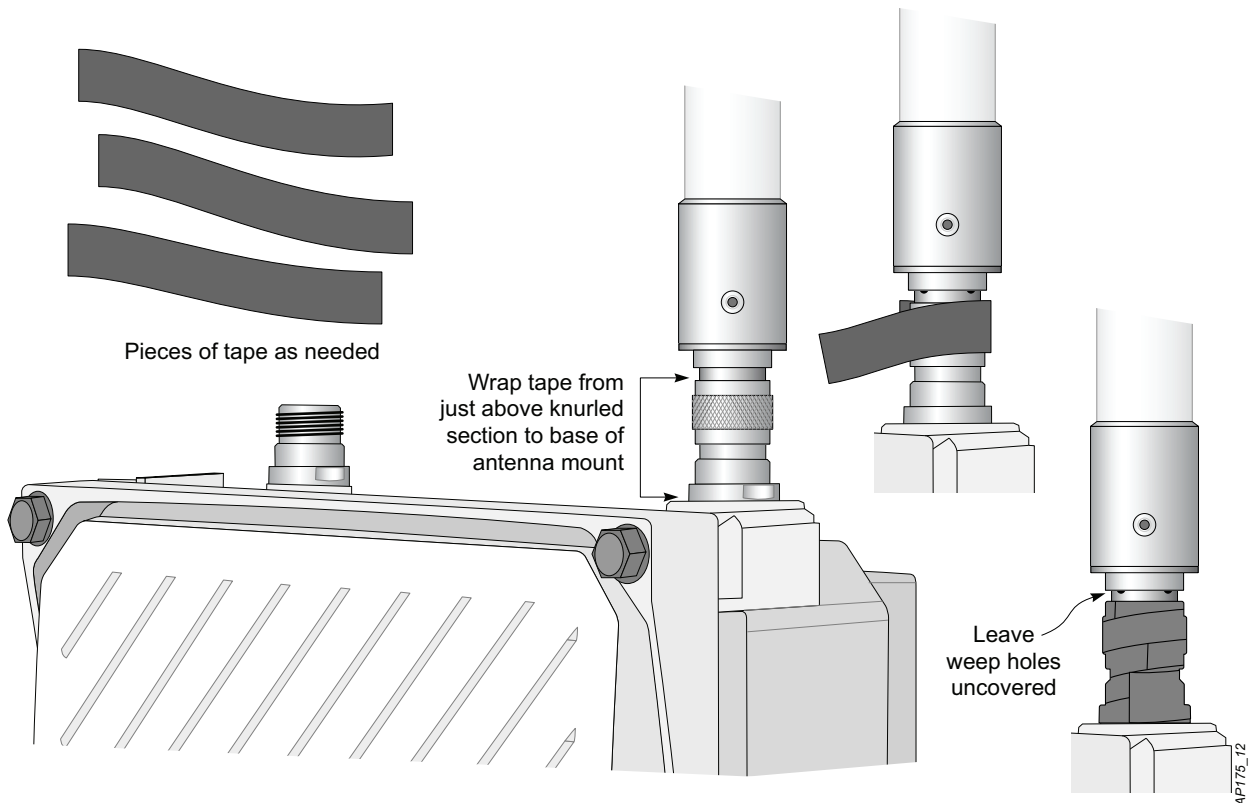

## Wrapping of Butyl Rubber

1. Cut a 3/4" (19 mm) strip of butyl rubber.
2. Wrap the strip of rubber around the taped connector (Figure 9)
3. Join the two ends by pushing them together until there is no longer a seam (Figure 10).

**Figure 9** Butyl Rubber Placement

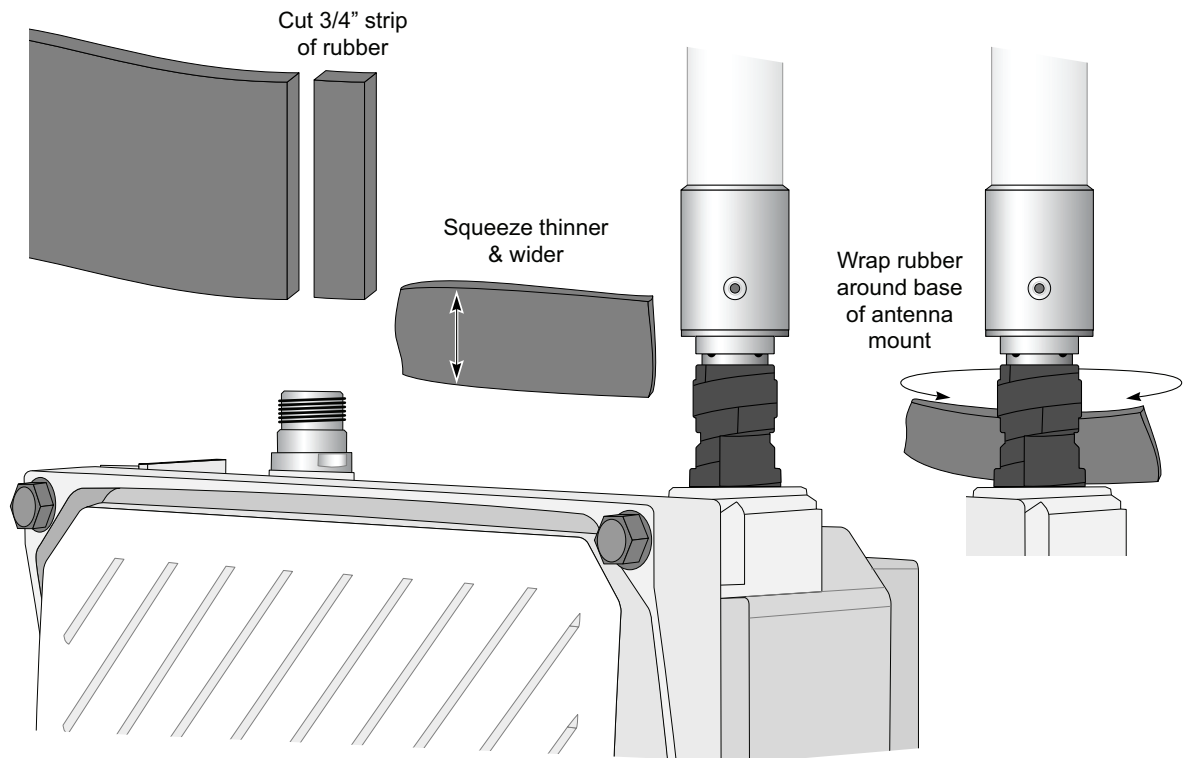

AP175\_13

**Figure 10** Butyl Rubber Wrap

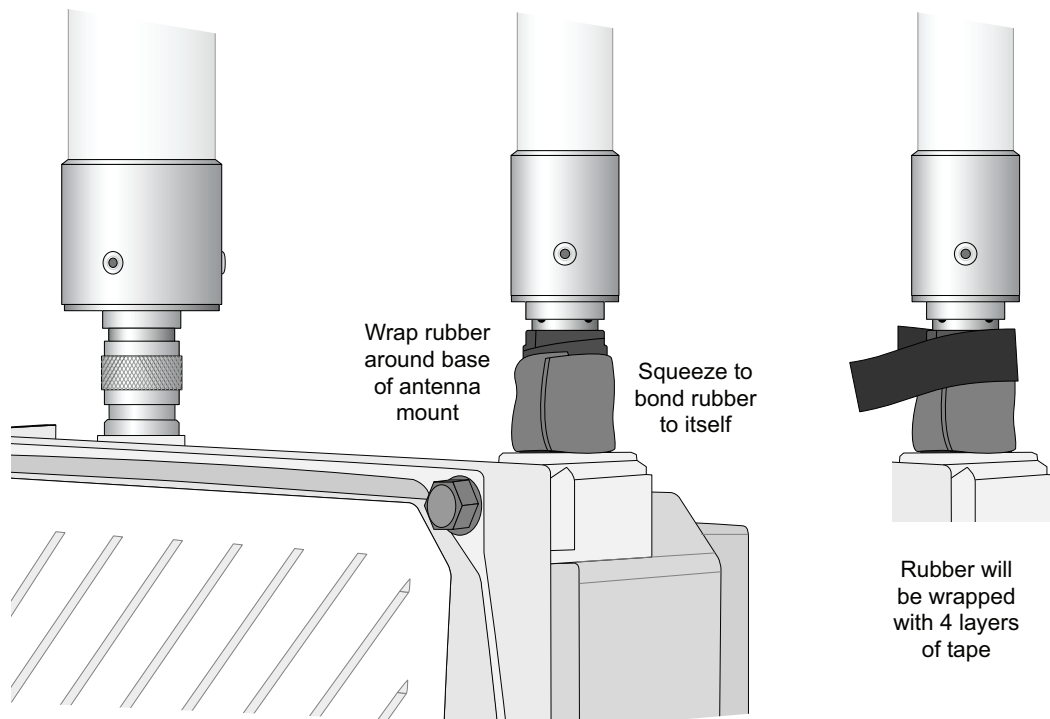

AP175\_14



## Second Wrapping of Tape

1. Cut a 4" (100 mm) strip of electrical tape from the roll.
2. Where you begin wrapping depends on the orientation of the antenna. Water should flow in the opposite direction of the wrapping to prevent water from entering the connector between the layers of tape.  
Therefore, if the antenna is facing up, you should begin wrapping at the AP end of the connector. This will ensure that your fourth and final layer will be layered correctly. Conversely, if your antenna is facing down, you should begin wrapping on the antenna end of the connector.
3. After completing the fourth layer of tape, check your work to ensure there are no places where water can collect. If there are, you must smooth out those areas with additional layers of tape or remove the weatherproofing and begin again.

**Figure 11** *Completed Wrapping (Antenna on Top of AP)*

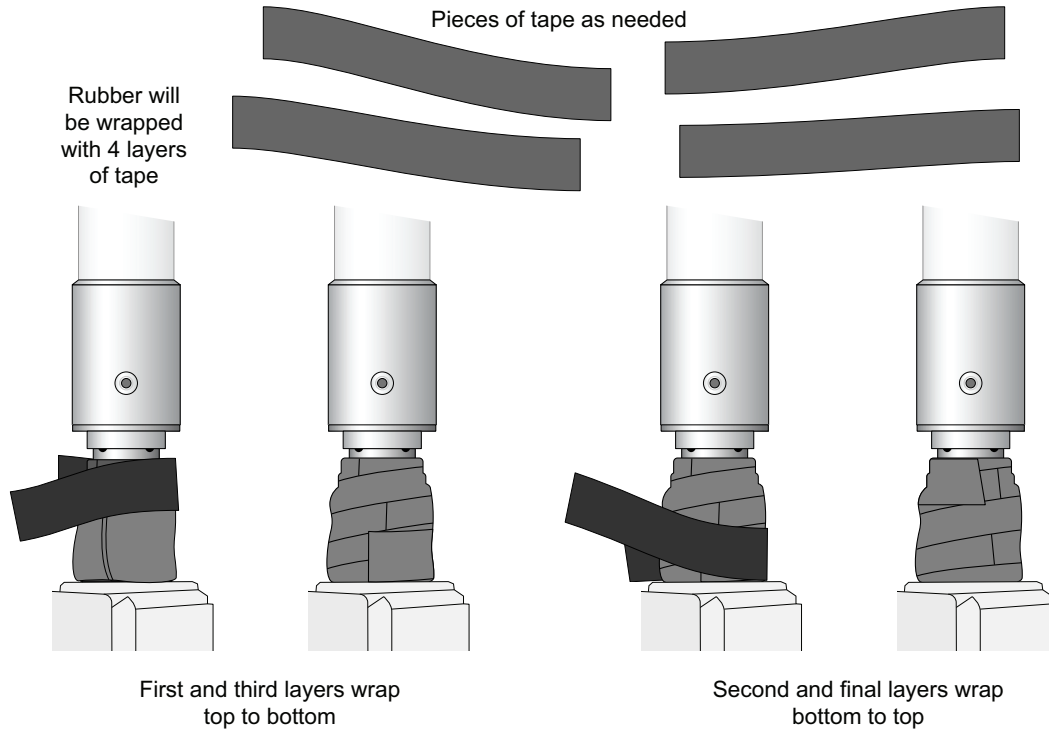

4. Repeat this process for all connectors.

## Weatherproofing Cable Connections

### First Wrapping of Tape

1. Prepare the antenna connector by cleaning and drying it.
2. Cut a 4" (100 mm) strip of electrical tape from the roll. Pre-cutting the tape into strips makes it easier to maneuver the tape around the connectors and other components but is not required.
3. Beginning at the top of the connector, tightly wrap the connection with a layer of the 3/4" (19mm) electrical tape. Overlap the tape to a half-width.
4. Repeat steps 3 and 4 until the wrapping extends all the way to the cable's insulation.

**Figure 12** *First Wrapping of Tape*

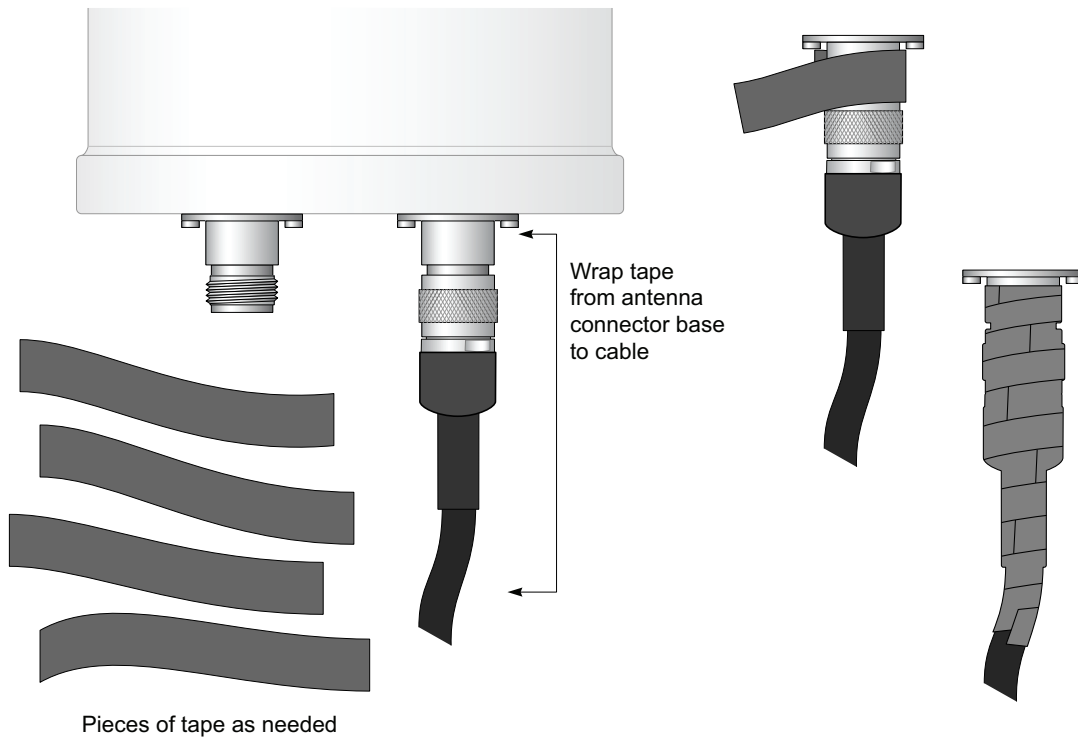

AP175\_17

## Wrapping of Butyl Rubber

1. Cut a piece of butyl rubber large enough to wrap around the connector and extended past the first layer of tape.
2. Wrap the strip of rubber around the taped connector (Figure 13)
3. Join the two ends by pushing them together until there is no longer a seam (Figure 14).

**Figure 13** Butyl Rubber Placement

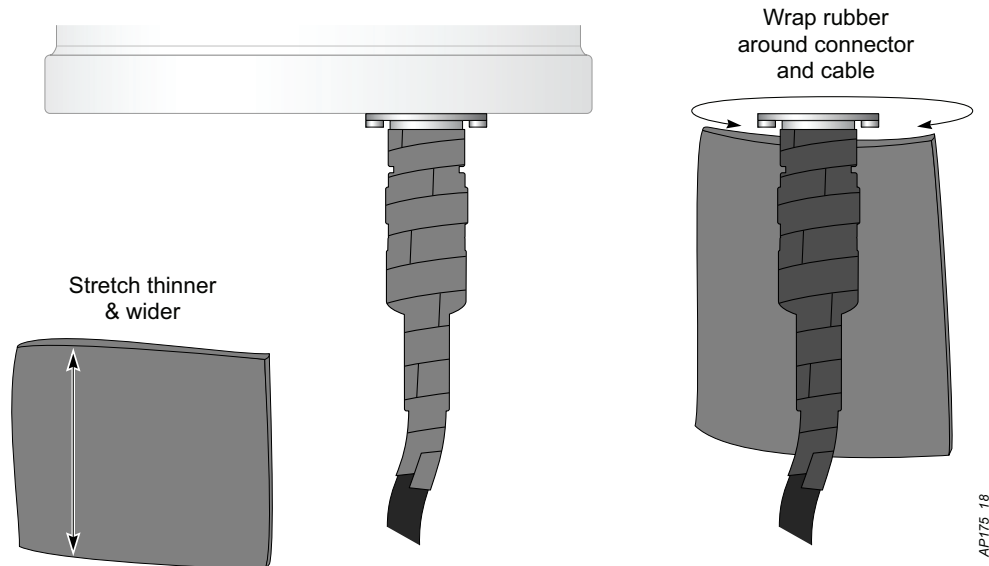

**Figure 14** Butyl Rubber Wrap

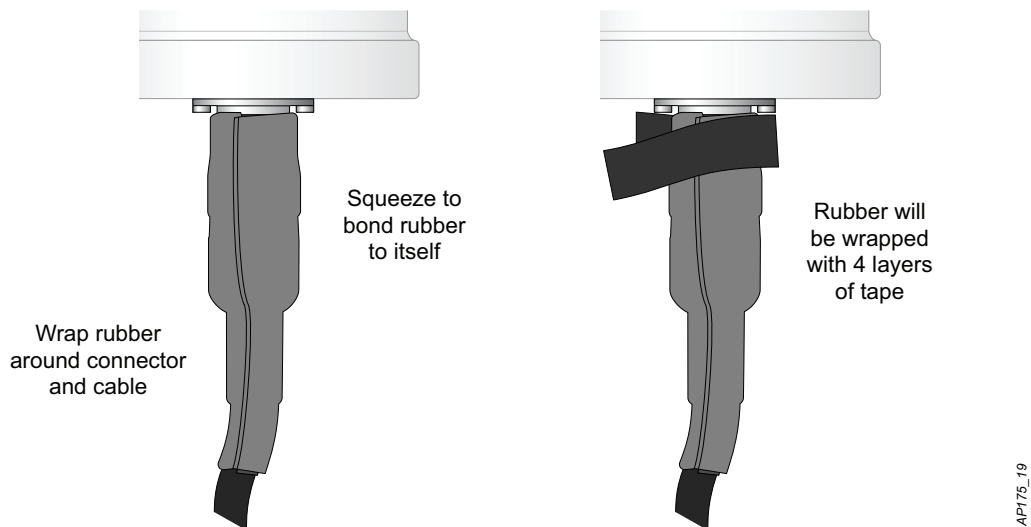

## Second Wrapping of Tape

1. Cut a 4" (100 mm) strip of electrical tape from the roll.
2. Using 3/4" (19mm) electrical tape, begin wrapping at the connector and create four layers.
3. After completing the fourth layer of tape, check your work to ensure there are no places where water can collect. If there are, you must smooth out those areas with additional layers of tape or remove the weatherproofing and begin again.

**Figure 15** *Completed Wrapping*

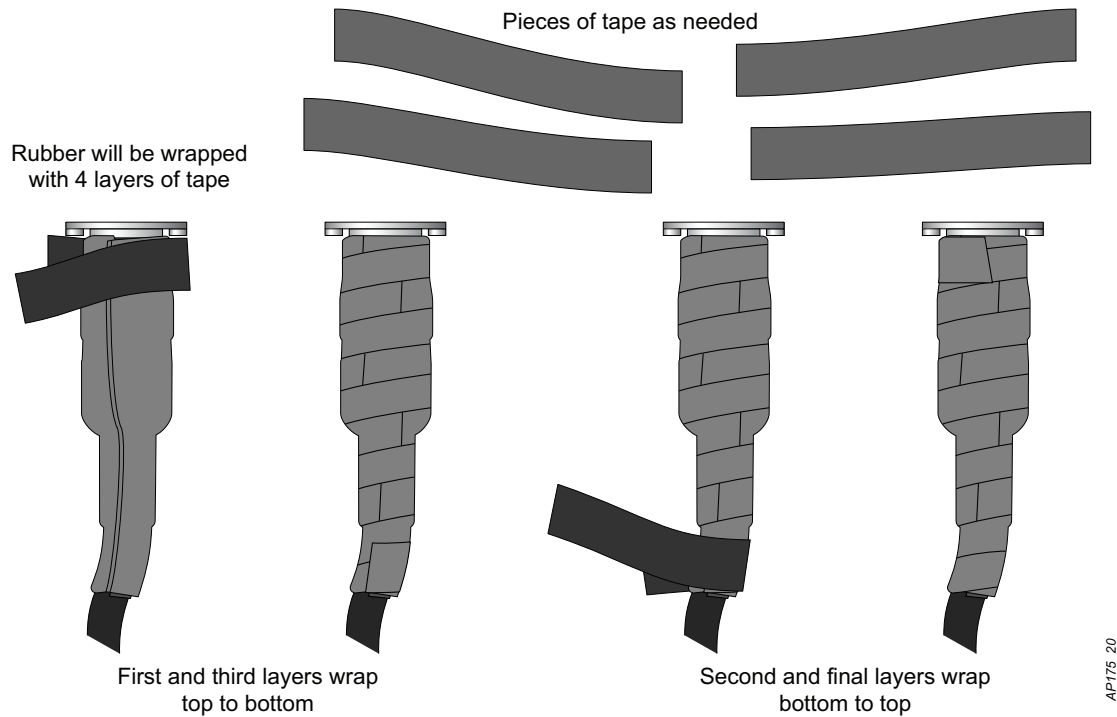

4. Repeat this process for all connectors.

## Installing the W-AP175

The W-AP175 can be installed on a wall or attached to a pole. The following section describes how to attach the necessary hardware to the AP and how to mount the AP in the selected location.

### Selecting the Installation Site

- The site should be located within at least a 60% range of the 1st fresnel zone without obstacles to provide line of sight (LOS) transmission, increase coverage capacity, and minimize the number of necessary sites.
- If no LOS is secured, areas in non-line-of-sight (NLOS) areas could be covered as well, but the distance of coverage and area of coverage are decreased; more sites are needed to provide coverage for same area than in the LOS scenario.
- Interference must be considered in site selection. The new site should avoid known interference, unless the interference is controllable.
- Keep the W-AP175 away from places that are susceptible to high temperature, dust, harmful gas, inflammable, explosive, electromagnetic interference (high power radar, radio station and transformer), unstable voltage, heavy vibration, or loud noise. In engineering design, the site should be selected according to the network planning and technical requirements of communications equipment, as well as the considerations such as climate, hydrology, geology, earthquake, electric power, and transportation.

## Installing the W-AP175 on a Pole

1. Attach the W-AP175 on the mounting bracket using the two M6 x30 bolts (with flat and spring washers) on each side of the mounting bracket.

**Figure 16** Attaching the mounting bracket to the AP

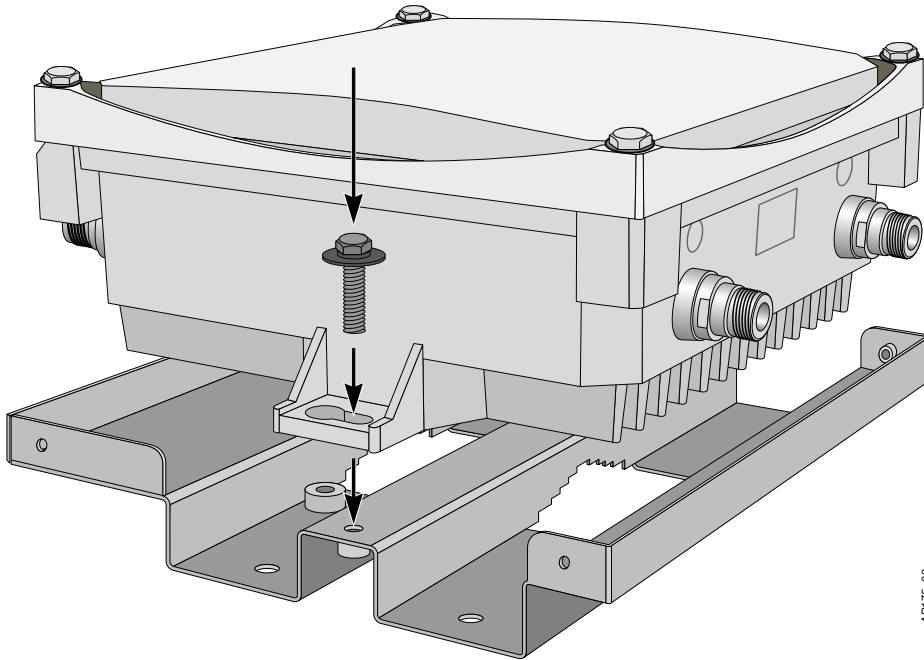

2. Attach the mounting bracket (with W-AP175) on the pole using four M8 x110 bolts (with flat washers, spring washers and nuts) and the pair of pole anchors.

**Figure 17** Attaching the mounting bracket to the pole

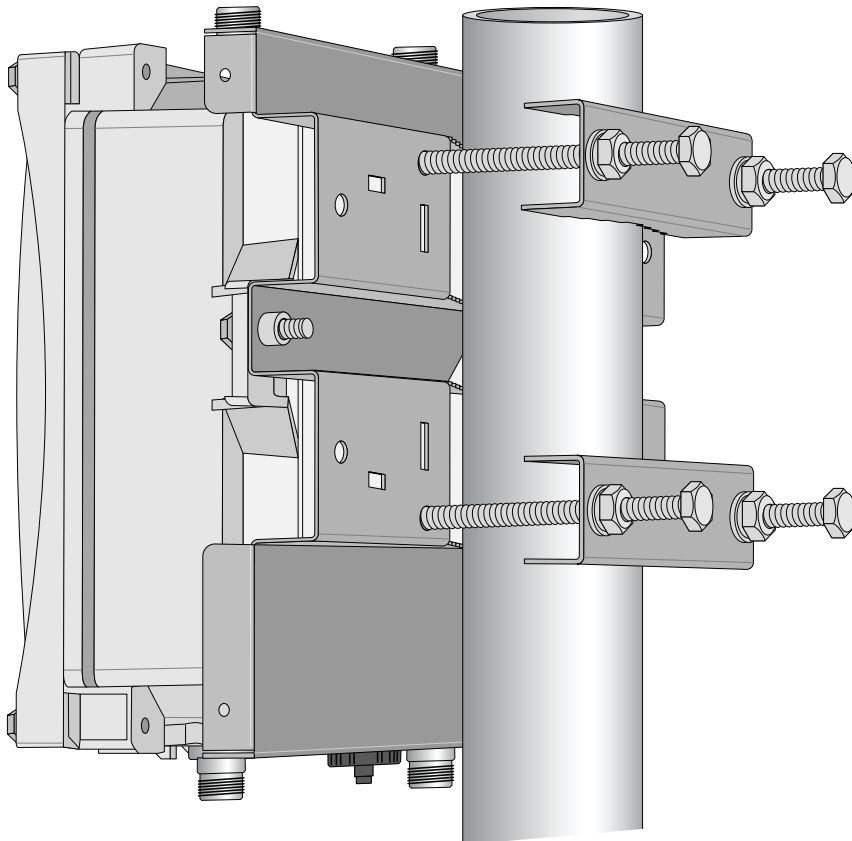

## Installing the W-AP175 on a Wall

1. Begin by marking the screw points on the wall in the location you have selected.
  - a. Put the mounting bracket on the installation position against the wall.
  - b. Mark four expansion screw holes on the wall.

**Figure 18** *Position of the screw holes*

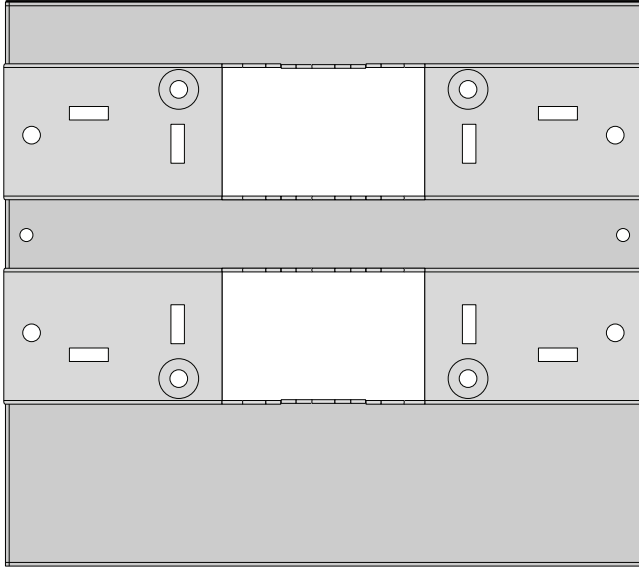

2. Use a drill to create four holes on the four markings you created in the previous step.
3. Install wall (masonry) anchors.
  - a. Insert a masonry anchor into each drilled hole.
  - b. Tap the flat end of the anchor with a rubber hammer until the anchor is flush with the wall surface.
4. Attach the mounting bracket to the wall.
  - a. Align the four holes in the mounting bracket with the anchors and insert four expansion screws through the installation holes into the anchors.
  - b. Adjust the position of the mounting bracket and tighten the expansion screws.
5. Attach the W-AP175 to the mounting bracket by inserting the two M6 x30 bolts (with flat and spring washers) through the installation holes, and tighten the bolts.

**Figure 19** Attaching the AP to the Mounting Bracket

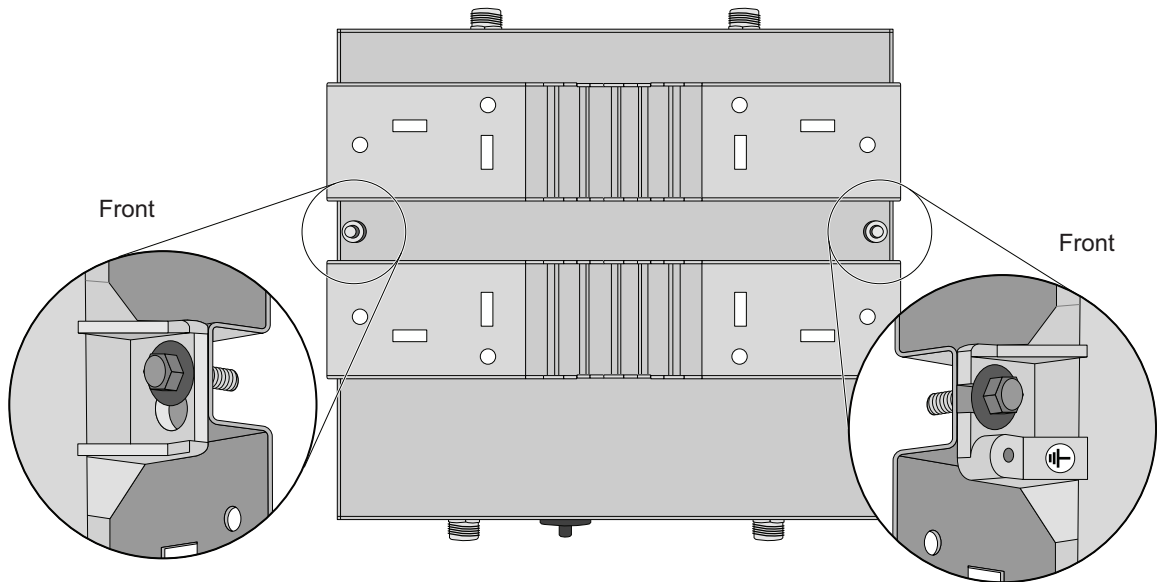

### Grounding the W-AP175

The grounding must be completed before powering up the W-AP175. The resistance of grounding wire should be less than 5 ohm and the grounding cable's cross-section area should be no less than 6 mm. The grounding hole is at the right side of the W-AP175.

**Figure 20** Grounding the W-AP175

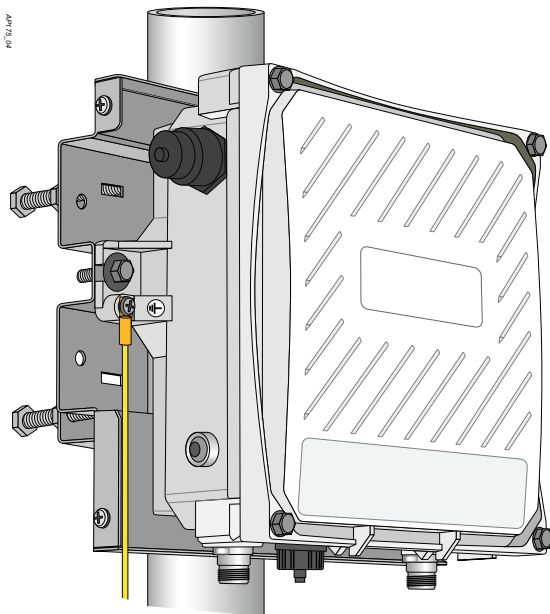

1. Peel the cover of one end of the grounding cable (green or yellow and green grounding cable with 6 mm cross-section area) and place the bare grounding cable into the copper lug, and press firmly with the crimping pliers.
2. Fasten the copper lug to the grounding hole on the W-AP175 with the M4 x12 bolt and external-tooth washer.

## Connecting the Ethernet Cable (W-AP175P)

To ensure that your outdoor access point (AP) maintains ethernet connectivity and Power over Ethernet (PoE), you must use the included weatherproof connector kit and install it using the steps below.



---

**WARNING:** Failure to use the included weatherproof connector kit can lead to connectivity and PoE issues.

---

**Figure 21** *Waterproof Ethernet Connector Cover*

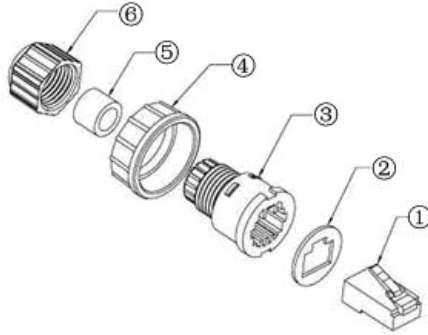

- |   |                             |   |             |
|---|-----------------------------|---|-------------|
| 1 | Shielded RJ45 connector     | 4 | Locknut     |
| 2 | Gasket Mat                  | 5 | Seal Ring   |
| 3 | Waterproof Connector Socket | 6 | Sealing Nut |

1. Remove the cover from the adhesive side of the gasket mat and place it over the weatherproof connector socket.
2. Place the locknut over the weatherproof connector socket.
3. Place the sealing nut over an ethernet cable (without a connector attached to the end).
4. Place the seal ring over the ethernet cable.
5. Insert the ethernet cable into the narrow end of the weatherproof connector socket and pass it through the opening on the wide end.
6. Using a crimping tool, attach the included shielded RJ45 connector.
7. Slide the seal ring up the ethernet cable and insert it into the narrow end of the weatherproof connector socket.
8. Pull the ethernet cable so the shielded RJ45 connector fits into the RJ45 shaped opening in the wide end of the weatherproof connector socket.
9. Slide the sealing nut over the narrow end of the weatherproof connector socket and hand tighten it.
10. Insert the ethernet cable connector into the ethernet interface and hand-tighten the locknut.
11. Water-proof the ethernet cable connection with electrical tape and butyl rubber.



## Connecting the Ethernet Cable (W-AP175AC/DC)

To ensure that your outdoor access point (AP) maintains ethernet connectivity and Power over Ethernet (PoE), you must use the included weatherproof connector kit and install it using the steps below.



**WARNING:** Failure to use the included weatherproof connector kit can lead to connectivity and PoE issues.

**Figure 22** *Waterproof Ethernet Connector Cover*

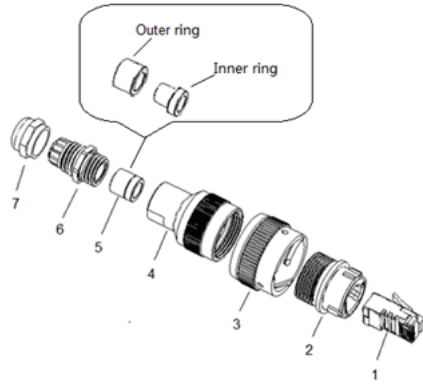

- |   |                             |   |              |
|---|-----------------------------|---|--------------|
| 1 | Shielded RJ45 connector     | 5 | Shield rings |
| 2 | Waterproof Connector Socket | 6 | Sealing Bolt |
| 3 | Locknut                     | 7 | Sealing Nut  |
| 4 | Clamp ring                  |   |              |

1. Hold the clamp ring (4) vertically, with the wide end facing up, and place the locknut (3) over it.
2. Drop the waterproof connector socket (2) into the locknut/clamp ring items (3,4), with the RJ45 connector opening facing up, and screw the socket into the threads on the clamp ring.
3. Place the sealing nut (7) over an ethernet cable (without a connector attached to the end).
4. Place the seal bolt (6) over the ethernet cable.
5. Strip off about 55mm (2 inches) of the outer ethernet cable sheath to expose the ground wire and other pair wires.
6. Insert all pair wires into the two shield rings (5).
7. Make the ground wire attach to the narrow end of the inner ring and place the outer ring over the narrow end of the inner ring.
8. Insert the ethernet cable into the narrow end of the clamp ring and pass it through the opening end of waterproof connector socket.
9. Using a crimping tool, attach the included shielded RJ45 connector.
10. Slide the shield rings up the ethernet cable and insert it into the narrow end of the clamp ring.
11. Pull the ethernet cable so the shielded RJ45 connector fits into the RJ45 shaped opening in the wide end of the weatherproof connector socket.
12. Slide the sealing bolt over the narrow end of the clamp ring and hand tighten it.
13. Thread the sealing nut onto the sealing bolt.
14. Insert the ethernet cable connector into the ethernet interface and hand-tighten the locknut.
15. Water-proof the ethernet cable connection with electrical tape and butyl rubber.

**Figure 23** *Connecting the Ethernet cable*

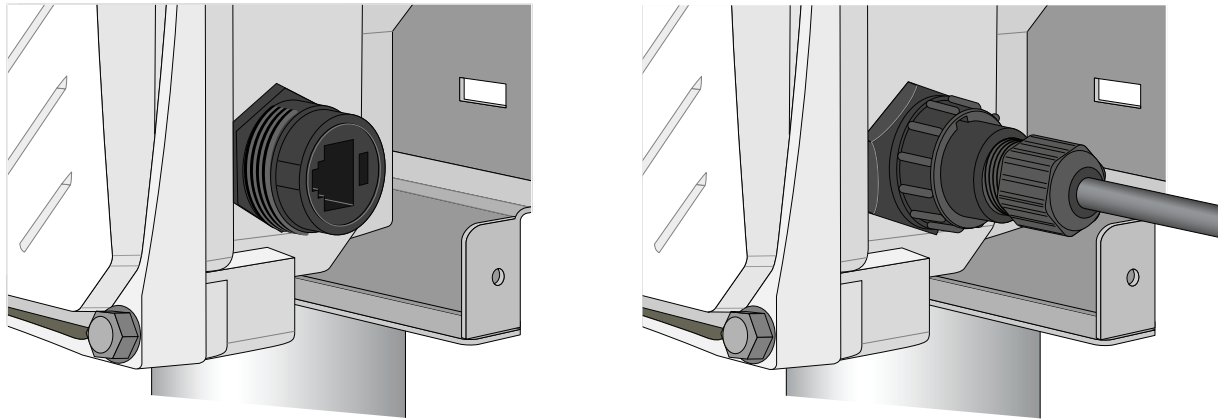

## Connecting the Power Cable (W-AP175 AC/DC)



---

**CAUTION:** Installation and service of Dell products should be performed by Professional Installers.

---

The W-AP175AC and W-AP175DC versions need an outdoor rated power cable to connect to a compatible AC or DC power source.



---

**NOTE:** The W-AP175 does not ship with any power cables; these are available as accessories and should be ordered separately. In addition to completed power cables, Dell also offers an outdoor rated AC and DC connector kit that can be used to connect a compatible power cable to the W-AP175.

---

- AC power source specifications (at W-AP175 interface): 100-240Vac, 100W
- DC power source specifications (at W-AP175 interface): 12-48Vdc, 100W
- AC power cable specifications (when using AC connector kit and custom cable): minimum voltage/current rating 250V/1A, diameter 6-12mm, rated for outdoor use
- DC power cable specifications (when using DC connector kit and custom cable): minimum voltage/current rating 60V/10A, diameter 6-12mm, rated for outdoor use

### Cable Connection Steps

1. Remove the protective cap on the power interface.
2. Insert the power cable connector into the power interface and hand-fasten the waterproof cover.
3. Water-proof the power cable connection with PVC insulation tape, adhesive insulation tape and strap.

## Attaching the Solar Shield to the W-AP175

Attach the solar shield to the W-AP175 by using the four M4 x16 (with flat and spring washers).

**Figure 24** Attaching the Solar Shield to the AP

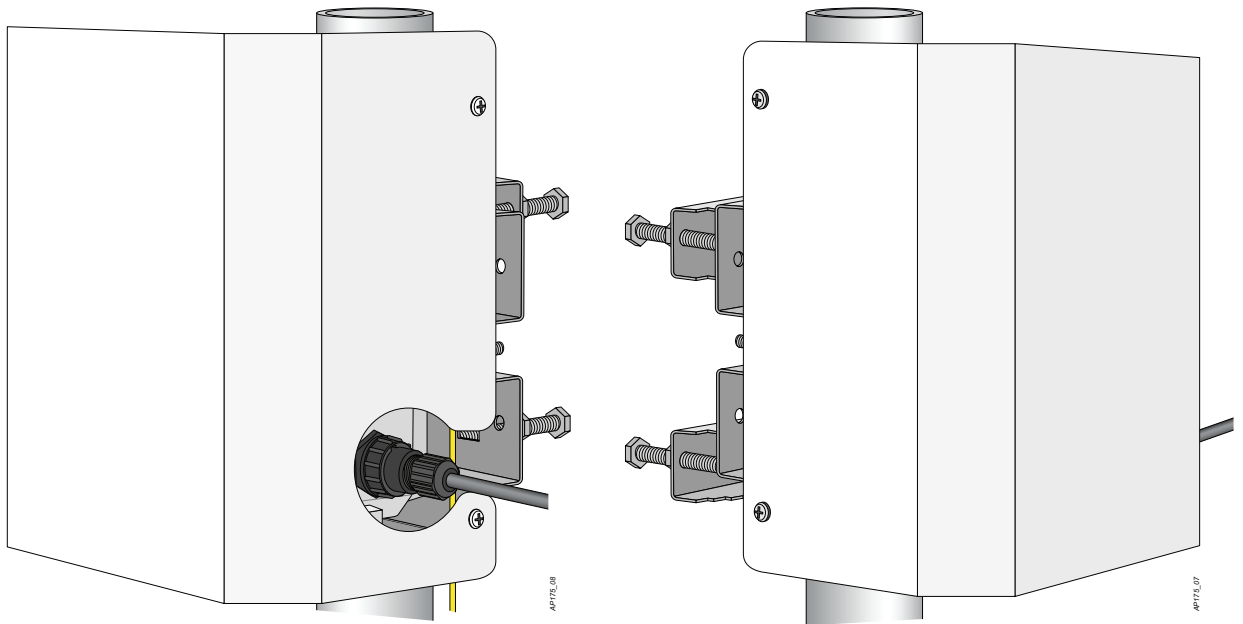

# Product Specifications

## Mechanical

- Dimensions (H x W x D)
  - 10.2 inches x 9.4 inches x 4.1 inches
  - 26 cm x 24 cm x 10.5 cm
- Weight: 7 lbs/3.25 kg
- Shipping Dimensions (H x W x D)
  - 12.9 inches x 12.6 inches x 11.8 inches
  - 33 cm x 32 cm x 30 cm
- Shipping Weight: 16.6 lbs/7.5 kg
- Temperature
  - Operating (W-API175P): -30°C to 60°C (-22°F to 140°F)
  - Operating (W-API175AC/DC): -40°C to 55°C (-40°F to 131°F)
  - Storage: -40°C to 70°C (-40°F to 158°F)
- Relative Humidity: 5% to 95% non-condensing
- Altitude: Up to 9,850ft (3,000 meters)
- Mounting: wall or pole mountable
- Antennas:
  - Quad, N-type female interfaces (2 x 2.4 GHz, 2 x 5GHz) for external antenna support (supports MIMO)
  - Feeder cable may be used for external antenna deployments
- Visual Status Indicators (LEDs): See [Table 2](#)

## Electrical

### Power In

- W-API175P: 48-volt DC 802.3at power over Ethernet (PoE+)
- W-API175AC: 100-240 volt AC from external AC power source
- W-API175DC: 12-48 volt DC from external DC power source
- Maximum power consumption: 18 watts (excludes power consumed by any POE device connected to and powered by the W-API175AC or W-API175DC)

### Power Out

- The AC and DC powered models provide an 802.3af POE power source (PSE) on the ethernet interface.

## Interfaces

- Network:
  - 1 x 10/100/1000BASE-T Ethernet (RJ-45), auto-sensing link speed and MDI/MDX
- Power:
  - 1 x DC power connector (in W-API175DC model only)
  - 1 x AC power connector (in W-API175AC model only)
- Antenna:
  - 4 x N-Type female antenna interfaces

- Other:
  - 1 x USB console interface

## Wireless LAN

- AP type: Dual-radio, dual-band 802.11n outdoor
- Supported frequency bands (country-specific restrictions apply):
  - 2.400 to 2.4835 GHz
  - 5.150 to 5.250 GHz
  - 5.250 to 5.350 GHz
  - 5.470 to 5.725 GHz
  - 5.725 to 5.850 GHz
- Available channels: Controller-managed, dependent upon configured regulatory domain
- Supported radio technologies:
  - 802.11b: Direct-sequence spread-spectrum (DSSS)
  - 802.11a/g/n: Orthogonal frequency division multiplexing (OFDM)
  - 802.11n: 2x2 MIMO with two spatial streams
- Supported modulation types:
  - 802.11b: BPSK, QPSK, CCK
  - 802.11a/g/n: BPSK, QPSK, 16-QAM, 64-QAM
- Transmit power: Configurable in increments of 0.5 dBm
- Maximum transmit power:
  - 2.4 GHz: 25 dBm (limited by local regulatory requirements)
  - 5 GHz: 25 dBm (limited by local regulatory requirements)
- Maximum ratio combining (MRC) for improved receiver performance
- Association rates (Mbps):
  - 802.11b: 1, 2, 5.5, 11
  - 802.11a/g: 6, 9, 12, 18, 24, 36, 48, 54
  - 802.11n: MCS0 - MCS15 (6.5 Mbps to 300 Mbps)
- 802.11n high-throughput (HT) support: HT 20/40
- 802.11n packet aggregation: A-MPDU, A-MSDU

## Safety and Regulatory Compliance

Dell provides a multi-language document containing country specific restrictions and additional safety and regulatory information for all Dell hardware products. The *Dell PowerConnect W-Series Safety, Environmental, and Regulatory Information* document is included with this product.



---

**CAUTION: RF Radiation Exposure Statement:** This equipment complies with FCC RF radiation exposure limits. This equipment should be installed and operated with a minimum distance of 13.78 inches (35 cm) between the radiator and your body for 2.4 GHz and 5 GHz operations. This transmitter must not be co-located or operating in conjunction with any other antenna or transmitter. When operated in the 5.15 to 5.25 GHz frequency range, this device is restricted to indoor use to reduce the potential for harmful interference with co-channel Mobile Satellite Systems.

---



---

**CAUTION:** Dell Access Points and the AP-LAR-1 lightning arrestor are required to be installed by a professional installer. The professional installer is responsible for ensuring that grounding is available and it meets applicable local and national electrical codes.

---



---

**WARNING:** Do not work on an AP and do not connect or disconnect cables during periods of lightning activity.

---

### FCC Class B Device

This equipment has been tested and found to comply with the limits for a Class B digital device, pursuant to part 15 of the FCC Rules. These limits are designed to provide reasonable protection against harmful interference in a residential installation. This equipment generates, uses and can radiate radio frequency energy and, if not installed and used in accordance with the instructions, may cause harmful interference to radio communications. However, there is no guarantee that interference will not occur in a particular installation. If this equipment does cause harmful interference to radio or television reception, which can be determined by turning the equipment off and on, the user is encouraged to try to correct the interference by one or more of the following measures:

- Reorient or relocate the receiving antenna.
- Increase the separation between the equipment and receiver.
- Connect the equipment into an outlet on a circuit different from that to which the receiver is connected.
- Consult the dealer or an experienced radio/ TV technician for help.

For a complete list of Country Specific Regulations please speak with your Dell Representative.

# Proper Disposal of Dell Equipment

For the most current information about Global Environmental Compliance and Dell products, see [dell.com](http://dell.com).

## Waste of Electrical and Electronic Equipment



Dell products at end of life are subject to separate collection and treatment in the EU Member States, Norway, and Switzerland and therefore are marked with the symbol shown at the left (crossed-out wheeie bin). The treatment applied at end of life of these products in these countries shall comply with the applicable national laws of countries implementing Directive 2002/96EC on Waste of Electrical and Electronic Equipment (WEEE).

## European Union RoHS



Dell products also comply with the EU Restriction of Hazardous Substances Directive 2002/95/EC (RoHS). EU RoHS restricts the use of specific hazardous materials in the manufacture of electrical and electronic equipment. Specifically, restricted materials under the RoHS Directive are Lead (including Solder used in printed circuit assemblies), Cadmium, Mercury, Hexavalent Chromium, and Bromine. Some Dell products are subject to the exemptions listed in RoHS Directive Annex 7 (Lead in solder used in printed circuit assemblies). Products and packaging will be marked with the “RoHS” label shown at the left indicating conformance to this Directive.

## China RoHS



Dell products also comply with China environmental declaration requirements and are labeled with the “EFUP 25” label shown at the left.

有毒有害物質聲明 Hazardous Materials Declaration						
部件名称 (Parts)	有毒有害物質或元素(Hazardous Substances)					
	铅 Lead (Pb)	汞 Mercury (Hg)	镉 Cadmium (Cd)	六价铬 Chromium VI Compounds (Cr6+)	多溴联苯 Polybrominated Biphenyls (PBB)	多溴二苯醚 Polybrominated Diphenyl Ether (PBDE)
电路板 PCA Board	O	O	O	O	O	O
机械组件 Mechanical Subassembly	X	O	O	O	O	O
O: 表示该有毒有害物質在该部件所有均质材料中的含量均在SJ/T11363-2006标准规定的限量要求以下。 This component does not contain this hazardous substance above the maximum concentration values in homogeneous materials specified in the SJ/T11363-2006 Industry Standard.						
X: 表示该有毒有害物質至少在该部件的某一均质材料中的含量超出SJ/T11363-2006标准规定的限量要求。 This component does contain this hazardous substance above the maximum concentration values in homogeneous materials specified in the SJ/T11363-2006 Industry Standard.						
对销售之日的所售产品,本表显示,供应链的电子产品信息产品可能包含这些物质。 This table shows where these substances may be found in the supply chain of electronic information products, as of the date of sale of the enclosed product.						
此标志为针对所涉及产品的环保使用期标志。 某些零部件会有一个不同的环保使用期(例如,电池单元模块)贴在其产品上。此环保使用期限只适用于产品是在产品手册中所规定的条件下工作。 The Environment-Friendly Use Period (EFUP) for all enclosed products and their parts are per the symbol shown here. The Environment-Friendly Use Period is valid only when the product is operated under the conditions defined in the product manual.						

TRA  
REGISTERED No:  
ER0055290/11  
  
DEALER No:  
DA0039425/10

Complies with  
IDA Standards  
200202320G

# Contacting Support

Website Support	
Main Website	<a href="http://dell.com">dell.com</a>
Support Website	<a href="http://support.dell.com">support.dell.com</a>
Dell Documentation	<a href="http://support.dell.com/manuals">support.dell.com/manuals</a>

## Copyright

© 2011 Aruba Networks, Inc. Aruba Networks trademarks include  , Aruba Networks®, Aruba Wireless Networks®, the registered Aruba the Mobile Edge Company logo, and Aruba Mobility Management System®. Dell™, the DELL™ logo, and PowerConnect™ are trademarks of Dell Inc.

All rights reserved. Specifications in this manual are subject to change without notice.

Originated in the USA. All other trademarks are the property of their respective owners.

## Open Source Code

Certain Aruba products include Open Source software code developed by third parties, including software code subject to the GNU General Public License (GPL), GNU Lesser General Public License (LGPL), or other Open Source Licenses. The Open Source code used can be found at this site:

[http://www.arubanetworks.com/open\\_source](http://www.arubanetworks.com/open_source)

## Legal Notice

The use of Aruba Networks, Inc. switching platforms and software, by all individuals or corporations, to terminate other vendors' VPN client devices constitutes complete acceptance of liability by that individual or corporation for this action and indemnifies, in full, Aruba Networks, Inc. from any and all legal actions that might be taken against it with respect to infringement of copyright on behalf of those vendors.